

LIFT TRUCK ATTACHMENT MAXI GRIP L/T



INSTRUCTION MANUAL

VALLEY CRAFT, INC. 2001 SOUTH HWY. 61, LAKE CITY, MN 55041 PH: 1-800-328-1480

11/02

Z41144A0

TABLE OF CONTENTS

A.	OPERATING INSTRUCTIONS	PG. 3
B.	SAFETY INFORMATION	PG. 4
C.	PARTS DIAGRAM & PARTS LIST	PG. 5-6
D.	CYLINDER PARTS LIST	PG. 7
E.	LOAD CENTER INFORMATION	PG. 8
F.	TROUBLESHOOTING GUIDE	PG. 9
G.	WARRANTY STATEMENT	PG. 10

A. Operating Instructions

NOTE: IT IS RECOMMENDED THAT ALL OPERATORS PRACTICE OPERATION OF THE DRUM GRIP AND ITS CONTROLS WITH AN EMPTY DRUM BEFORE USING IT ON FULL DRUMS TO FAMILIARIZE THEMSELVES WITH THE MACHINE AND TO DEVELOP SAFE WORKING HABITS.

1. Insert forks of lift truck into fork tubes of drum grip.
2. Attach safety chain by wrapping it around carriage and clipping safety hook.
3. Attach hydraulic quick couplers on 48" long hoses to those on lift truck auxiliary control valve.
4. Advance lift truck until jaws of the drum grip center around the drum.
5. Grip drums in center at all times.
6. Activate the clamping function with the auxiliary control valve on the lift truck.
7. If drum grip needs to be removed from forklift, unhook hydraulic quick couplers, remove chain from around carriage and back away from unit.

B. Safety Information

NOTE: IT IS RECOMMENDED THAT ALL OPERATORS PRACTICE OPERATION OF THE DRUM GRIP AND ITS CONTROLS WITH AN EMPTY DRUM BEFORE USING IT ON FULL DRUMS TO FAMILIARIZE THEMSELVES WITH THE MACHINE AND TO DEVELOP SAFE WORKING HABITS.

1. **CAUTION!** Too much pressure applied to drum will cause crushing. Operator must visually monitor pressure.
2. To avoid accidents, never activate the clamping function while the forklift is in motion.
4. Maximum lifting capacity is 2,000 lbs. Actual capacity is limited by the size of the lift truck counter-balancing the load. Always follow lift truck manufacturer's specifications.
5. The Maxi-Grip L/T is designed for handling steel drums and other rigid cylinders 13"-24" in diameter and should not be used for handling plastic or fiber drums.

PARTS BREAKDOWN **(MECHANICAL COMPONENTS)**

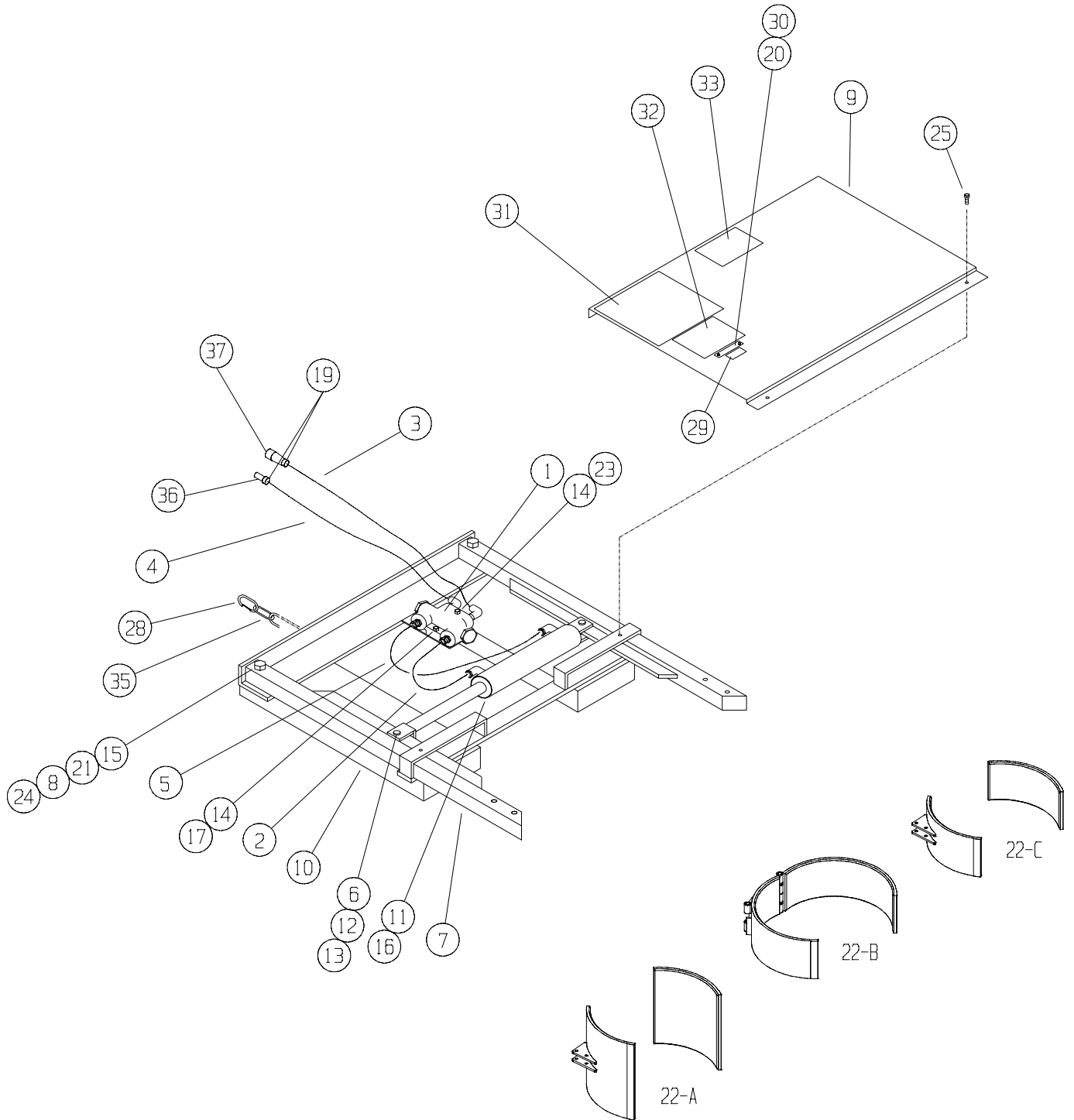

PARTS LIST

ITEM	PART NUMBER	DESCRIPTION	QTY.
1	F61329A0	VALVE ASSY/SAE	1
2	Z20736A8	HOSE-20.00/613	1
3	F61311A8	HOSE-48.00/613/649	1
4	F61312A7	HOSE-48.00/613/648	1
5	F61303A6	HOSE-23.00/613	1
6	F70392B2	PIN-YOKE CYL	2
7	F70712C3	ARM WLDMT-JAW	2
8	Z10267A6	BUSH-MACH 5/8X14GAX1-1/8	2
9	F72550C4	COVER	1
10	F72583C5	F W	1
11	F74400C9	CYL ASSY	1
12	Z10010A6	BUSH-MACH 3/4X1-GAX1-1/4	2
13	Z10552A6	PIN-SPG 5/32X1-1/2	2
14	Z10036A6	NUT-HEX KEPS 5/16-18	2
15	Z10050A7	NUT-NYL NE 5/8-18	2
16	Z20616A6	FTG 90 6801-4-4- NW0	2
17	Z10124A9	S-HHC 5/16-18X1-1/4	1
19	Z20597A5	FTG STR 6400-4-6-0	2
20	F74350C2	STD WLDMT/300 XL	1
21	F70727C6	BRACE WLDMT-STD/300	1
22-A	F72926C1	GIANT JAW	2
22-B	F72927C0	DRUM HUGGER JAW	2
22-C	F72925C2	STANDARD JAW	2
23	Z10321A0	S-HHC 5/16-18X2-1/4	1
24	Z10370A0	WASHER-5/8 FLATX1-1/2X1/4	2
25	Z10387A1	S-HWH #10-24X3/8	6
28	Z30513A6	SNAP-WIRE 3/8 ZP	2
29	Z41487A6	DECAL-LOAD CAP 2000	1
30	Z40473A3	TAG/VC SERIAL	1
31	Z40786A5	DECAL-INST	1
32	Z40796A3	DECAL-CAUTION	1
33	Z40901A5	LABEL-VALLEYCRAFT	1
35	F30200A0	CHAIN-60" DG	1
36	Z20666A6	CPLR NIPPLE #6	1
37	Z20665A7	CPLR BODY #6	1

CYLINDER ASSEMBLY (PART# F74400C9)
PARTS BREAKDOWN

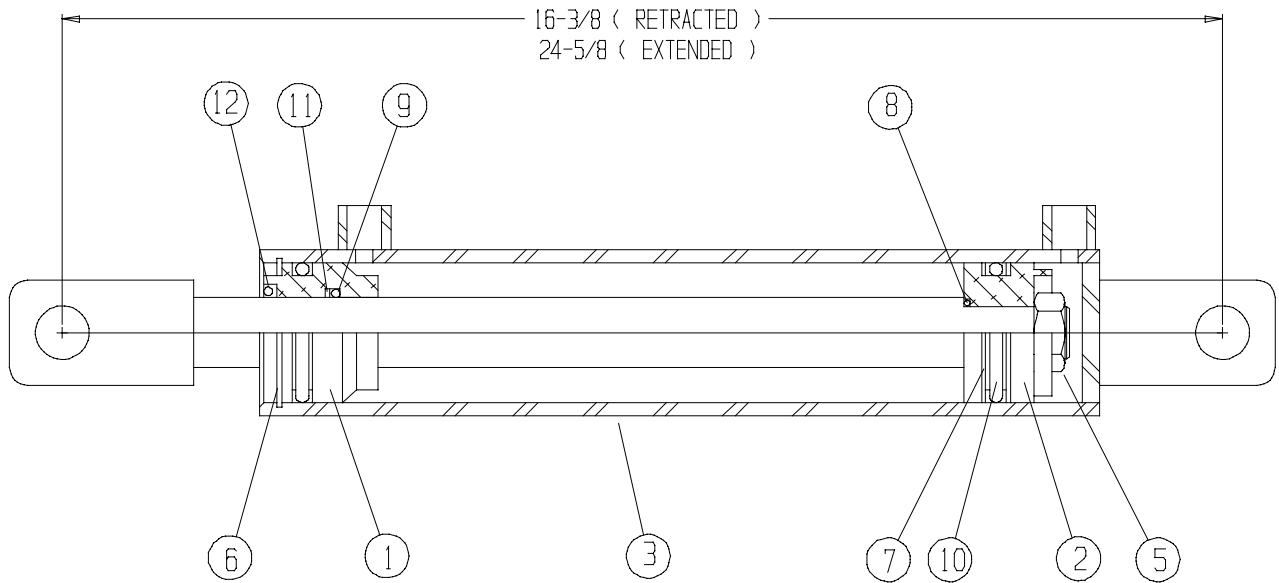

ITEM	PART NUMBER	DESCRIPTION	QTY.
1	F20007A6	2" CYLINDER HEAD	1
2	F20008A5	2" CYLINDER PISTON	1
3	F60999A2	CYLINDER CASING	1
5	Z10038A4	LOCK-NUT 3/4"-16	1
6	Z10228A4	2" RETAINING RING	1
7-12	F20041A4	CYLINDER SEAL KIT	
7	Z20043A6	BACK-UP (8-326)	2
8	Z20107A9	O-RING (APR116)	1
9	Z20108A8	O-RING (APR214)	1
10	Z20112A2	O-RING (APR326)	2
11	Z20115A9	BACK-UP RING (AN6246)	1
12	Z20116A8	WIPER (05BR124-100)	1

LOAD CENTER INFORMATION

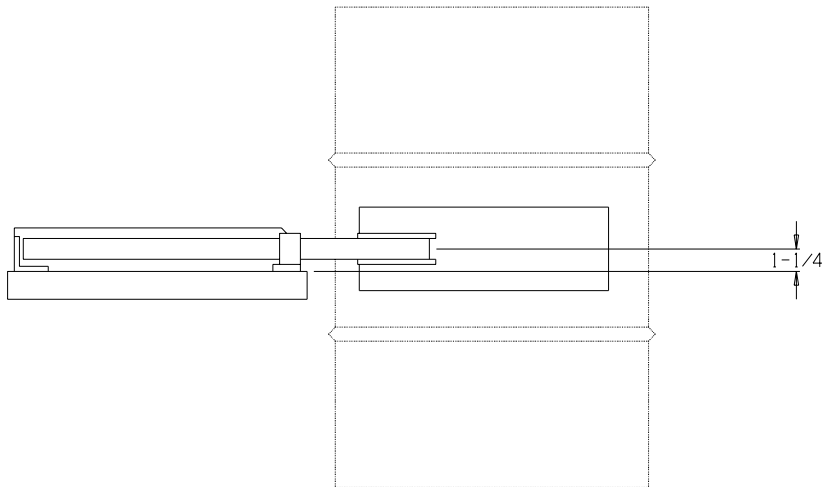
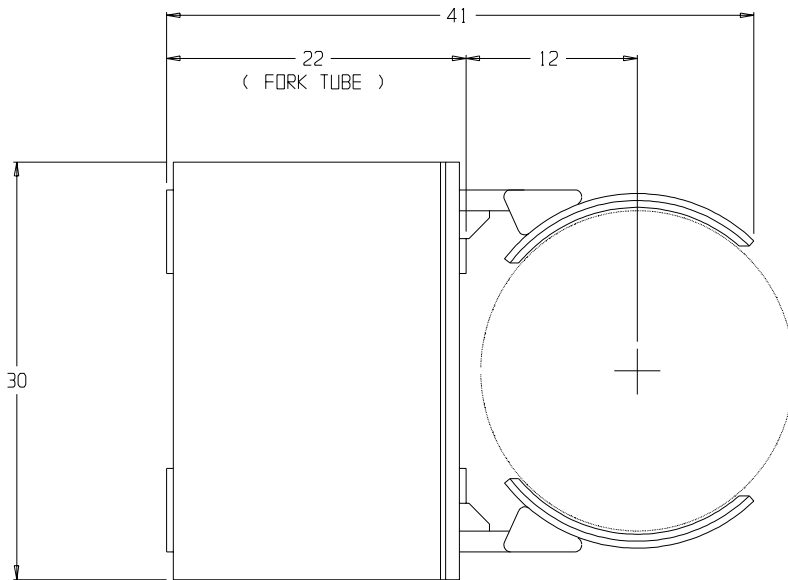

NOTES

LOAD CAPACITY= 2,000 LBS.

WEIGHT = 205 LBS.

CONTACT LIFT TRUCK MANUFACTURER FOR DOWNRATED CAPACITY

TROUBLESHOOTING GUIDE

PROBLEM	POSSIBLE CAUSE	SOLUTION
Difficult to attach Quick couplers to Auxiliary valve	Built-up pressure	Shut off forklift and work auxiliary valve Back and forth a few times to release Pressure
Unit is crushing drums	Too much pressure applied Flow from forklift to drum grip Is too high to control	Grip drum just to the point that the drum Starts to distort. Practice makes perfect! Install a flow restrictor valve on forklift (contact forklift manufacturer)
Cylinder leaking	Worn/old O-rings	Refer to parts list and order seal kit to repair cylinder

Warranty & Limitation of Liability

Valley Craft products are warranted for a period of one (1) year from date of shipment from Valley Craft's plant to be free from defects in material and workmanship under correct use, normal operating and proper application. However, parts of other than Valley Craft manufacture are subject ONLY to the original manufacturer's warranty. Valley Craft's obligation under warranty shall be limited to repair or exchange, at Valley Craft's option, FOB origin factory, of any Valley Craft product or part which proves to be defective as provided herein. Valley Craft reserves the right to either inspect the product at Buyer's location, or require it to be returned to the factory for inspection. The warranty contained herein does not extend to goods damaged, or subject to accident, abuse or misuse after shipment from Valley Craft's factory, nor to goods altered or repaired by anyone other than an authorized Valley Craft representative.

Buyer or user shall not alter, modify or use a Valley Craft product for anything other than its intended function. Valley Craft shall not in any way be responsible for the consequences of any such alteration, modification or misuse.

VALLEY CRAFT MAKES NO EXPRESS WARRANTIES OTHER THAN THOSE WHICH ARE SPECIFICALLY DESCRIBED HEREIN. Any description of the goods sold hereunder, including any references to Buyer's specifications and any descriptions in catalogs, circulars and other written material published by Valley Craft, is for the sole purpose of identifying such goods and shall not create an express warranty that the goods shall conform to such descriptions.

THIS WARRANTY IS EXPRESSLY IN LIEU OF ALL OTHER WARRANTIES, EXPRESS OR IMPLIED. THERE ARE NO IMPLIED WARRANTIES OF MERCHANTABILITY OR FITNESS FOR A PARTICULAR PURPOSE. THIS WARRANTY STATES VALLEY CRAFT'S ENTIRE AND EXCLUSIVE LIABILITY, AND BUYER'S EXCLUSIVE REMEDY FOR ANY CLAIM FOR DAMAGES IN CONNECTION WITH VALLEY CRAFT PRODUCTS, THEIR DESIGN, SUITABILITY FOR USE, INSTALLATION OR OPERATION OR FOR ANY CLAIMED DEFECTS. VALLEY CRAFT WILL IN NO EVENT BE LIABLE FOR INCIDENTAL OR CONSEQUENTIAL DAMAGES WHATSOEVER, NOR FOR ANY SUM IN EXCESS OF THE PRICE RECEIVED FOR THE GOODS FOR WHICH LIABILITY IS CLAIMED.

Technical Assistance/Warranty Procedure

What's Covered:

- Parts and Labor to correct manufacturer's defect within one year of purchase.
- Freight Cost

What's Not:

- Normal wear items (seal kits, bearings, tires, etc.)

What Voids the Warranty:

- Dirt/Grime that directly causes malfunction of product
- Abuse (i.e. Overloading, damaged, not properly maintained, etc.)
- Product altered by customer

*See "Items not Under Warranty" below for items that have the warranty voided.

Items Under Warranty (less than one year old):

- Warranty replacement parts are provided only when the problem can be identified with near certainty. If not, the customer will return item to Valley Craft, freight collect, for troubleshooting and/or repair. When repaired, product will be returned to customer, freight prepaid. Otherwise, customer may call local authorized service technician for assistance. . Under this arrangement, replacement parts will be sent at no charge but labor costs will NOT be covered.

Items NOT Under Warranty (greater than one year old or *having warranty voided):

- Customer will return item to Valley Craft, freight prepaid, for troubleshooting and/or repair. Valley Craft will call customer with \$\$ estimate of parts and labor for approval before repairing. Product will be returned to customer, freight collect.

Or

- Customer may call local authorized service technician for repairs at their own expense.

24008 1A2