

# ***LIFT TRUCK ATTACHMENT DOUBLE MAXI-GRIP S/P***



## **INSTRUCTION MANUAL**

VALLEY CRAFT, INC. 2001 SOUTH HWY. 61, LAKE CITY, MN 55041 PH: 1-800-328-1480

12/02

Z41147A7

## **TABLE OF CONTENTS**

<b>A.</b>	<b>OPERATING INSTRUCTIONS</b>	<b>PG. 3</b>
<b>B.</b>	<b>SAFETY INFORMATION</b>	<b>PG. 4</b>
<b>C.</b>	<b>MAINTENANCE INFORMATION</b>	<b>PG. 5</b>
<b>D.</b>	<b>BATTERY INSTALLATION INSTRUCTIONS</b>	<b>PG. 6</b>
<b>E.</b>	<b>BATTERY CHARGING INSTRUCTIONS</b>	<b>PG. 7</b>
<b>F.</b>	<b>PARTS DIAGRAM &amp; PARTS LIST</b>	<b>PG. 8-10</b>
<b>G.</b>	<b>CONTROL BOX DIAGRAM</b>	<b>PG. 11</b>
<b>H.</b>	<b>CYLINDER PARTS LIST</b>	<b>PG. 12</b>
<b>I.</b>	<b>HYDRAULIC SCHEMATICS</b>	<b>PG. 13</b>
<b>J.</b>	<b>LOAD CENTER INFORMATION</b>	<b>PG. 14</b>
<b>K.</b>	<b>RELIEF VALVE ADJUSTMENT PROCEDURE</b>	<b>PG. 15</b>
<b>L.</b>	<b>TROUBLESHOOTING CHART</b>	<b>PG. 16</b>
<b>M.</b>	<b>WARRANTY STATEMENT</b>	<b>PG. 17</b>
<b>N.</b>	<b>MATERIAL SAFETY DATA SHEETS</b>	<b>PG. 18-29</b>

## **A. Operating Instructions**

**NOTE: IT IS RECOMMENDED THAT ALL OPERATORS PRACTICE OPERATION OF THE DRUM GRIP AND ITS CONTROLS WITH AN EMPTY DRUM BEFORE USING IT ON FULL DRUMS TO FAMILIARIZE THEMSELVES WITH THE MACHINE AND TO DEVELOP SAFE WORKING HABITS.**

1. **IMPORTANT!** Remove solid plug on hydraulic reservoir and install breather cap (included in the Power Pak) for proper air venting.
2. Insert forks of lift truck into fork tube of drum grip.
3. Attach safety chain (included in Power Pak) to clevis on rear on frame. Wrap chain around the forklift of carriage and clip the safety hook.
4. Secure control box magnetically to any steel surface near the forklift drivers seat.
5. Advance lift truck until jaws of the drum grip center around the drum.
6. Grip drum in center at all times.
7. Activate clamping pressure by depressing the “ON” switch and “clamp” switch at the same time (clamping function requires the use of the two switches to guard against opening the jaws accidentally.)
8. If drum grip needs to be removed from forklift, set unit down, remove safety chain from around carriage, replace control box unit, and back away from the drum grip.

## **B. Safety Information**

**NOTE: IT IS RECOMMENDED THAT ALL OPERATORS PRACTICE OPERATION OF THE DRUM GRIP AND ITS CONTROLS WITH AN EMPTY DRUM BEFORE USING IT ON FULL DRUMS TO FAMILIARIZE THEMSELVES WITH THE MACHINE AND TO DEVELOP SAFE WORKING HABITS.**

1. **CAUTION!** Too much pressure applied to drum will cause crushing. Operator must visually monitor pressure.
2. To avoid accidents, never activate the clamping function while the forklift is in motion.
3. Maximum lifting capacity is 2,000 lbs. Actual capacity is limited by the size of the lift truck counter-balancing the load. Always follow lift truck manufacturer’s specifications.
4. The Double Maxi Grip is designed for handling steel or fiber drums and other rigid cylinders 14” - 28” in diameter. It should not be used for handling plastic drums.

## C. Maintenance Tips

1. **DANGER !** Disconnect all electrical supply sources before servicing. Hazardous voltage will cause severe injury or death.
2. Use 12 Volt deep-cycle batteries only. BCI group 27, 500- 600 cold cranking amps. Peak capacity at 25 amps at 80 degrees F: 120-160 minutes. Dimensions of each battery to be 12-1/4" long x 6-3/4" wide x 9-5/8" high (to top of terminal).
3. Check hydraulic fluid every 40 hours or before using the machine after long set-aside periods. Correct fluid level is 1 to 2 inches from top of fluid fill/breather cap. Do not overfill. **Use Dexron automatic transmission fluid only!**

## D. Battery Installation Instructions

1. Place two 12 volt deep cycle batteries into battery compartment.
2. Hook up battery cables to the proper terminals (see drawing below)
3. Attach red wire to the positive terminal (charger will not function properly unless this wire is connected).
4. Tighten wing nuts on battery terminals.

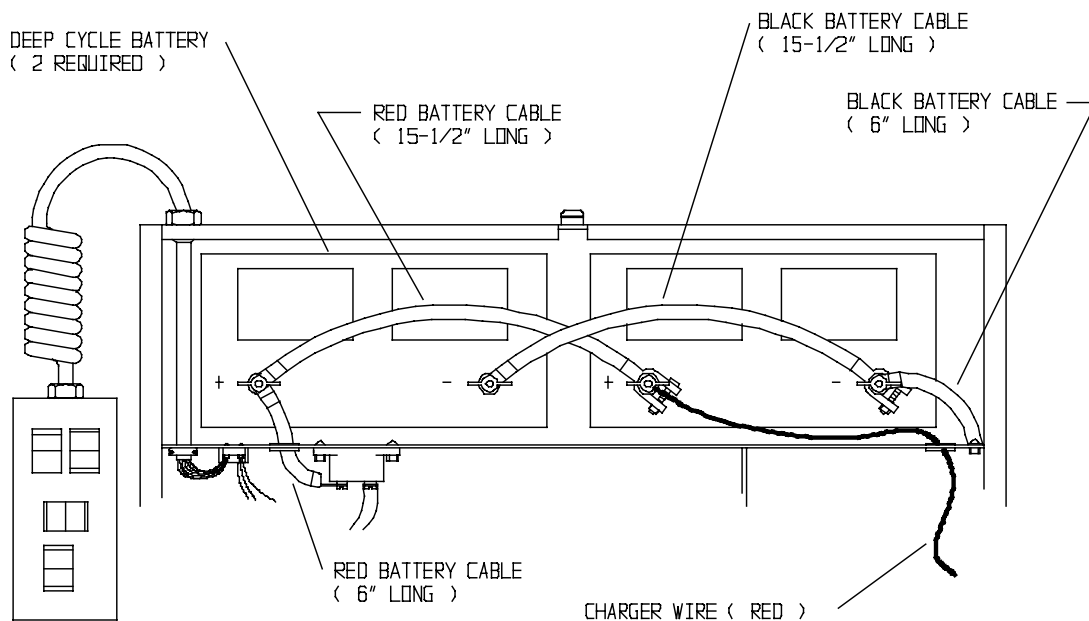

## **E. Battery Charging Instructions**

1. Read charger operating instructions manual before charging.
2. Plug a grounded extension cord into built-in receptacle in Power Pak and plug into outlet.
3. The drum grip is charged fully automatically, and can be left unattended while charging.
4. When re-charging is accomplished, unplug extension cord from Power Pak.

### **NOTES:**

- A. Generally, batteries will require equal charging to work time (ex. One hour of machine use = one hour of re-charging time).
- B. It is not recommended that alternate charging devices be used.
- C. To extend battery life, it is recommended that the batteries occasionally experience a full discharge. Doing this prevents the battery from developing a “memory” for a lesser charge.
- D. **CAUTION!** To avoid shock or burn, never touch the unit while recharging.

# PARTS BREAKDOWN

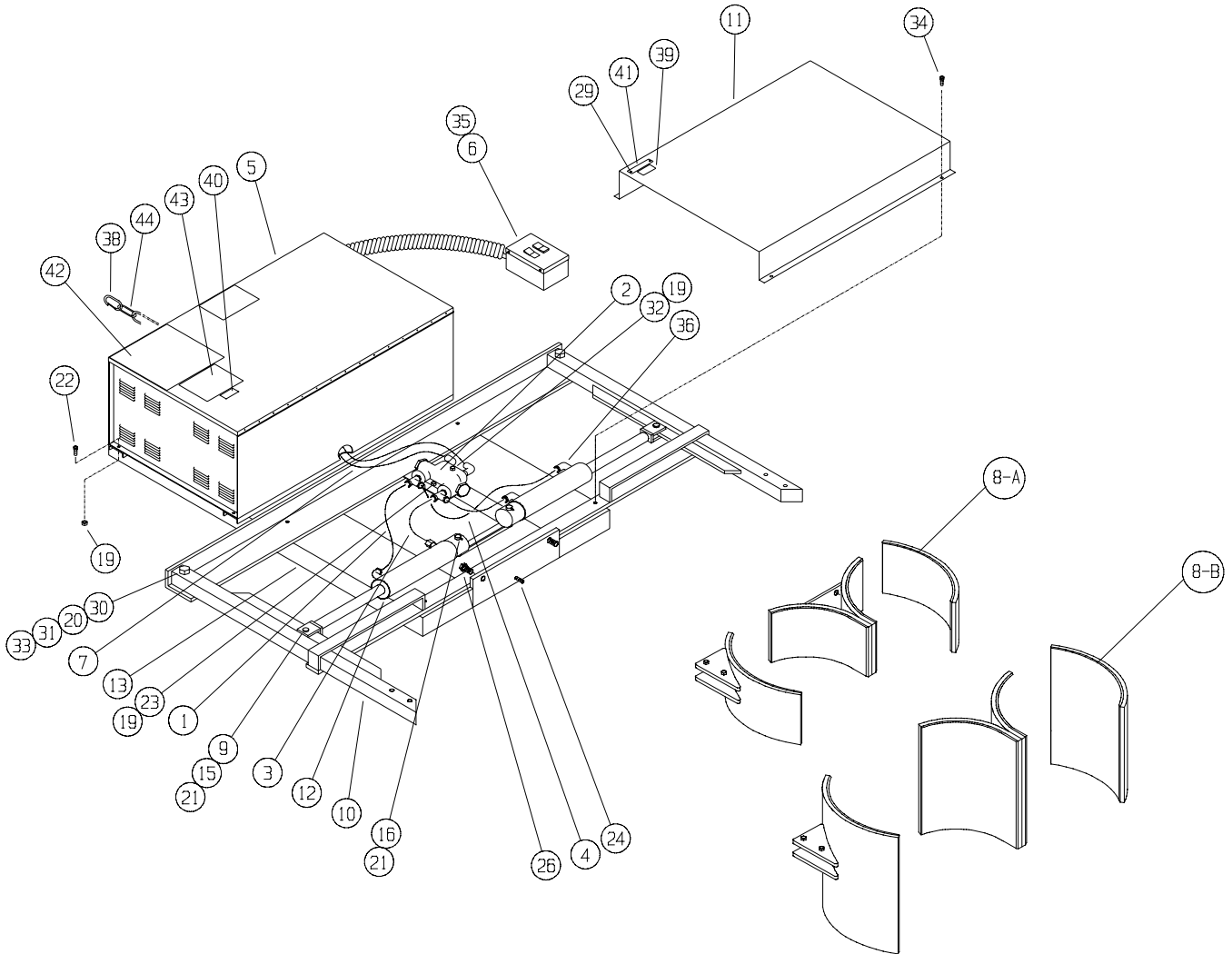

**PARTS LIST**

<b>ITEM</b>	<b>PART NUMBER</b>	<b>DESCRIPTION</b>	<b>QTY.</b>
1	Z20736A8	HOSE-20.00/613	2
2	F61335A4	VALVE ASSY L/O FIBER	1
3	F61310A9	HOSE-13.00/613	2
5	F62664B2	PP-ASSY/SAE	1
6	F62666A0	CTRL BOX ASSY-MAXI	1
7	F61321A8	HOSE-24.00/613/649	1
8-A	F72925C2	JAW-STANDARD	2
8-B	F72926C1	JAW-GIANT	2
9	F70392B2	PIN-YOKE CYL	2
10	F70672C1	ARM WLDMT JAW	2
11	F70849C9	COVER	1
12	F74402C7	CYL ASSY-JAW	1
13	F72643C3	F W/MAXI S/P DBL	1
15	Z10010A6	BUSH-MACH 3/4X10GAX1-1/4	2
16	Z10011A5	BUSH-MACH 1X18GAX1-1/2	4
18	Z10026A8	NUT-HEX JAM 3/8-16	1
19	Z10036A6	NUT-HEX KEPS 5/16-18	6
21	Z10072A1	PIN-SPT 1/4X1-1/2	2
22	Z10122A1	S-HHC 5/16-18-3/4	4
23	Z10125A8	S-HHC 5/16-18X1-1/2	1
24	Z10134A7	S-HHC 3/8-16X1-1/2	1
26	Z10161A3	S-HHC 5/8-18X2 HT	2
27	Z10214A0	WASHER-3/8 LOCK MD	1
29	Z10222A0	RIVET-POP 1/8X1/4	2
30	Z1-243A5	S-HHC 5/8-18X3-1/2 HT	2
31	Z10267A6	BUSH-MACH 5/8X14GAX1-1/8	2
32	Z10321A0	S-HHC 5/16-18X2-1/4	1
33	Z10370A0	WASHER-5/8X14GAX1-1/8	2
34	Z10387A1	S-HWH #10-24X3/8	4
35	Z00462A0	NUT-LOCK ELEC 1/2-14	1
36	Z20616a6	FTG 90 6801-4-4 NOW	2
37	F61353A6	HOSE-22.00/613/648	1
38	Z30513A6	SNAP-WIRE 3/8 ZP	2
39	Z40456A4	DECAL-CAUTION	1
40	Z41487A6	DECAL-LOAD CAP 2000	1
41	Z40473A3	TAG/VC	1
42	Z40787A4	DECAL-INST	1
43	Z40796A3	DECAL-CAUTION/HYD	1
44	F30200A0	CHAIN-60"	1
45	F61294A2	HOSE-30.00/613/648	1
46	Z20615A7	FTG STR 6400-4-4-0	2

# **POWER PAK ASSEMBLY (PART# F62664B2)**

## **PARTS BREAKDOWN**

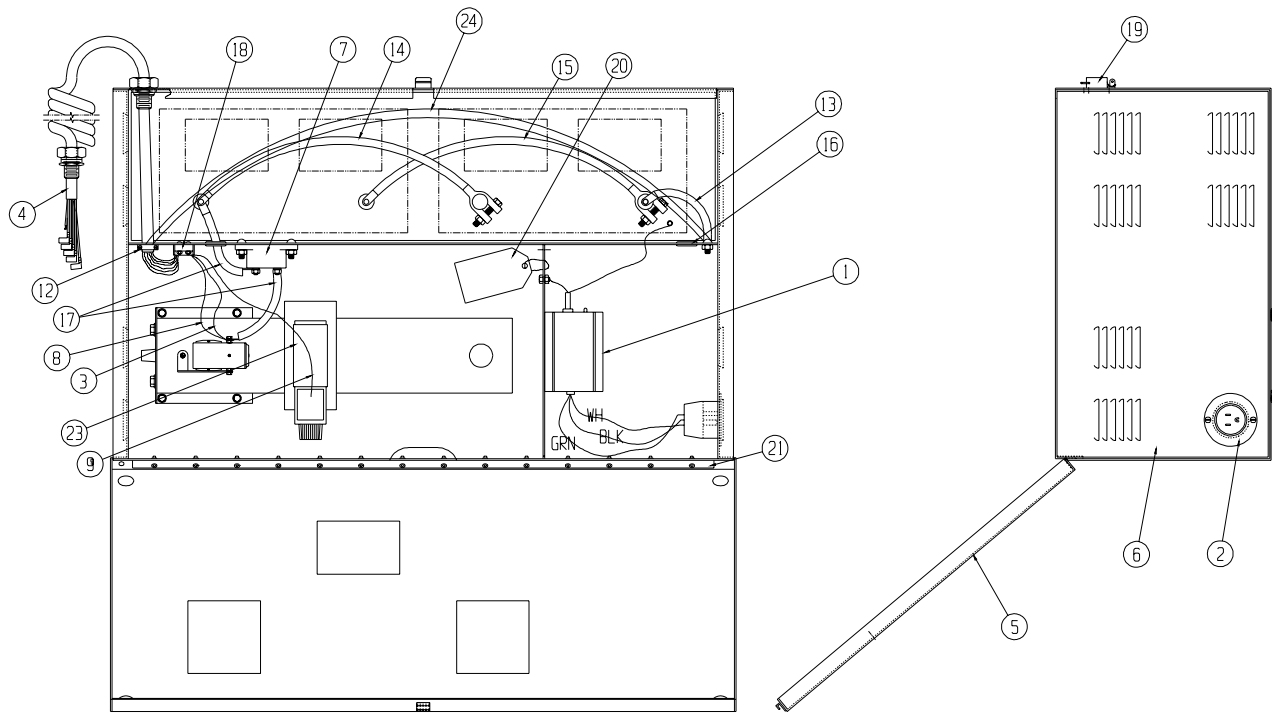

ITEM	PART NUMBER	DESCRIPTION	QTY
1	Z00227A7	BATTERY CHARGER	1
2	Z00120A4	PLUG ASSEMBLY-125V	1
3	F62762A3	WIRE ASSY-14GAX8 BROWN	1
4	F62663A3	CORD ASSEMBLY	1
5	F72661C0	COVER	1
6	F72662C9	ENCLOSURE WLDMT	1
7	Z00008A1	CIRCUIT BREAKER CLA-150	1
8	F62763A2	WIRE ASSY-14GAX8 BLACK	1
9	F62764A1	WIRE ASSY-14GAX10 GREEN	1
12	Z00097A3	CONNECTOR-STRAIGHT 1/2"	1
13	Z00111A5	BATTERY CABLE-BLACK 6"	1
14	Z00113A3	BATTERY CABLE-RED 15 1/2"	1
15	Z00114A2	BATTERY CABLE-BLACK 15 1/2"	1
16	Z00116A0	GROMMET-.625 I.D.	2
17	Z00117A9	BATTERY CABLE-RED 6"	2
18	Z00121A3	TERMINAL BLOCK 6-141	1
19	Z30401A1	LATCH	1
20	Z40537A7	INSTRUCTIONS/VENT PLUG	1
21	Z50055A8	1/16" CONTINUOUS HINGE	1
23	F61305A4	POWER PAK 2POS/4WAY 12V	1
24	Z00540A0	CABLE-BAT BLK 32"	1

# CONTROL BOX DIAGRAM (PART# F62666A0)

TOP VIEW-COVER

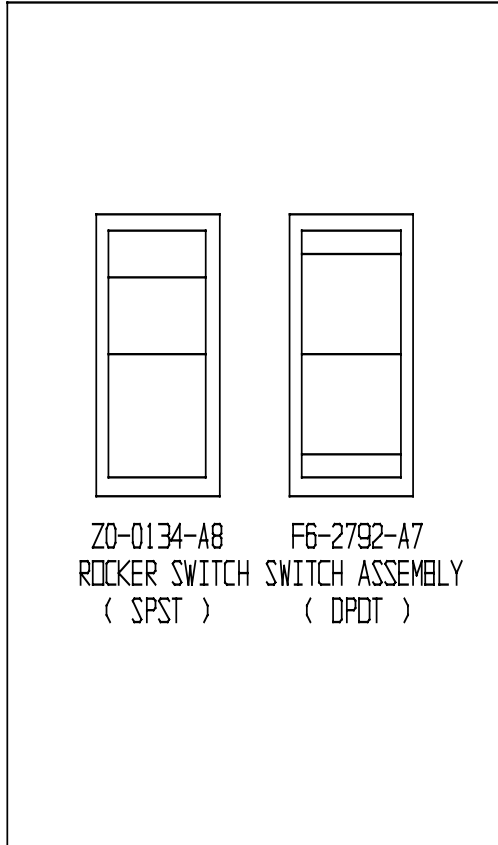

BOTTOM VIEW-COVER

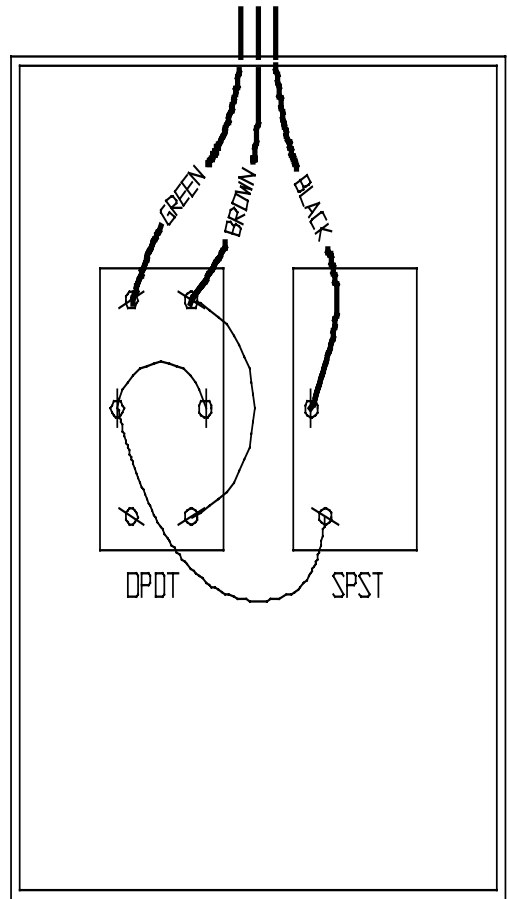

**CYLINDER ASSEMBLY (PART# F74402C7)**  
**PARTS BREAKDOWN**

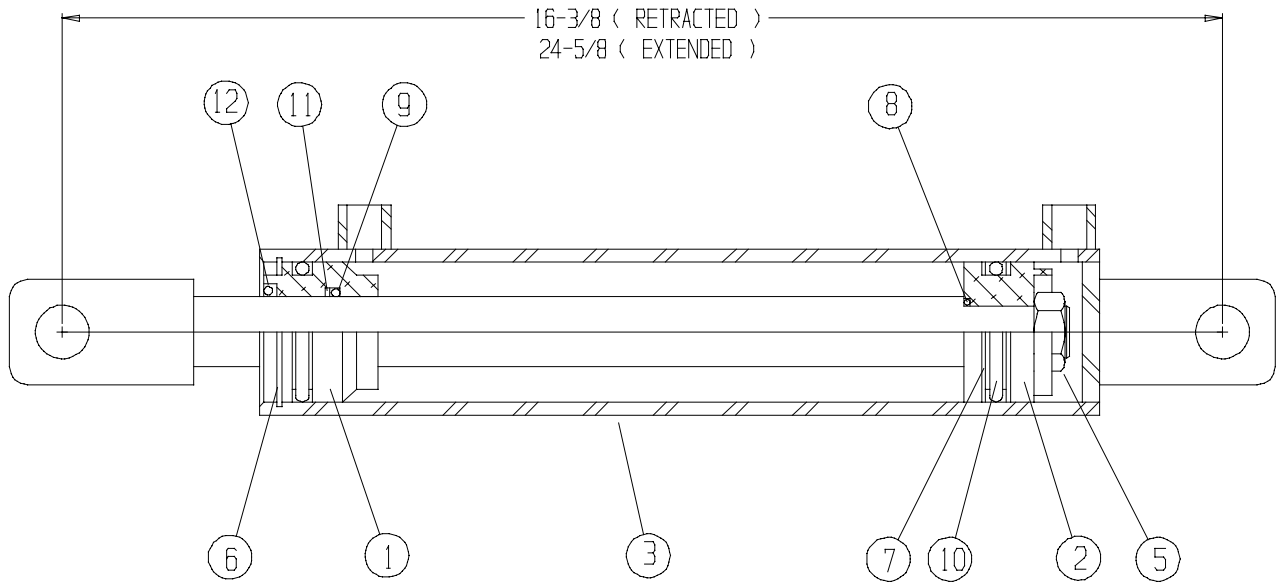

ITEM	PART NUMBER	DESCRIPTION	QTY.
1	F20007A6	2" CYLINDER HEAD	1
2	F20008A5	2" CYLINDER PISTON	1
3	F61001A0	CYLINDER CASING	1
5	Z10038A4	LOCK-NUT 3/4"-16	1
6	Z10228A4	2" RETAINING RING	1
7-12	F20041A4	CYLINDER SEAL KIT	
7	Z20043A6	BACK-UP (8-326)	2
8	Z20107A9	O'RING (APR116)	1
9	Z20108A8	O'RING (APR214)	1
10	Z20112A2	O'RING (APR326)	2
11	Z20115A9	BACK-UP RING (AN6246)	1
12	Z20116A8	WIPER (05BR124-100)	1

# HYDRAULIC SCHEMATIC

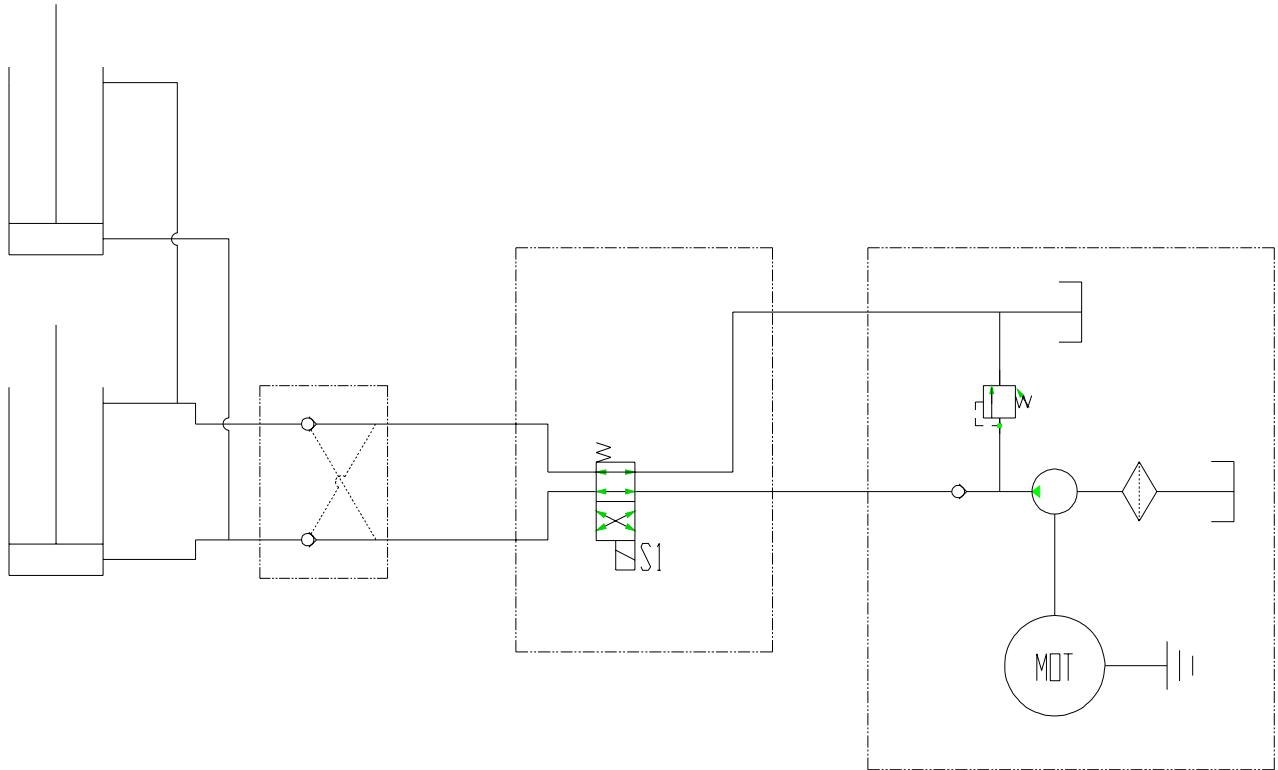

## **LOAD CENTER INFORMATION**

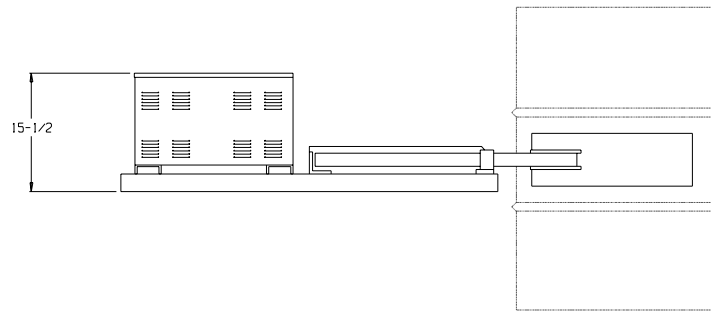
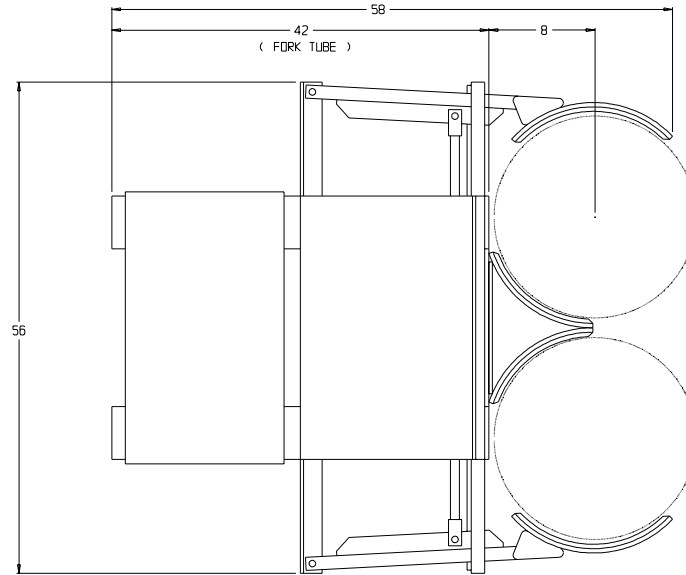

**NOTES:**  
LOAD CAPACITY= 2,000 LBS.  
WEIGHT = 385 LBS. WITH STANDARD JAWS  
CONTACT LIFT TRUCK MANUFACTURER FOR DOWNRATED CAPACITY.

# **RELIEF VALVE ADJUSTMENT PROCEDURE**

1. LOOSEN JAM NUT.
2. TURN SCREW CLOCKWISE TO INCREASE PRESSURE.
3. TURN SCREW COUNTER-CLOCKWISE TO DECREASE PRESSURE.
4. TIGHTEN JAM NUT.

*NOTE: OUTLET PORT FLOW MUST BE BLOCKED TO MAKE RELIEF VALVE OPERATE WHILE ADJUSTING.*

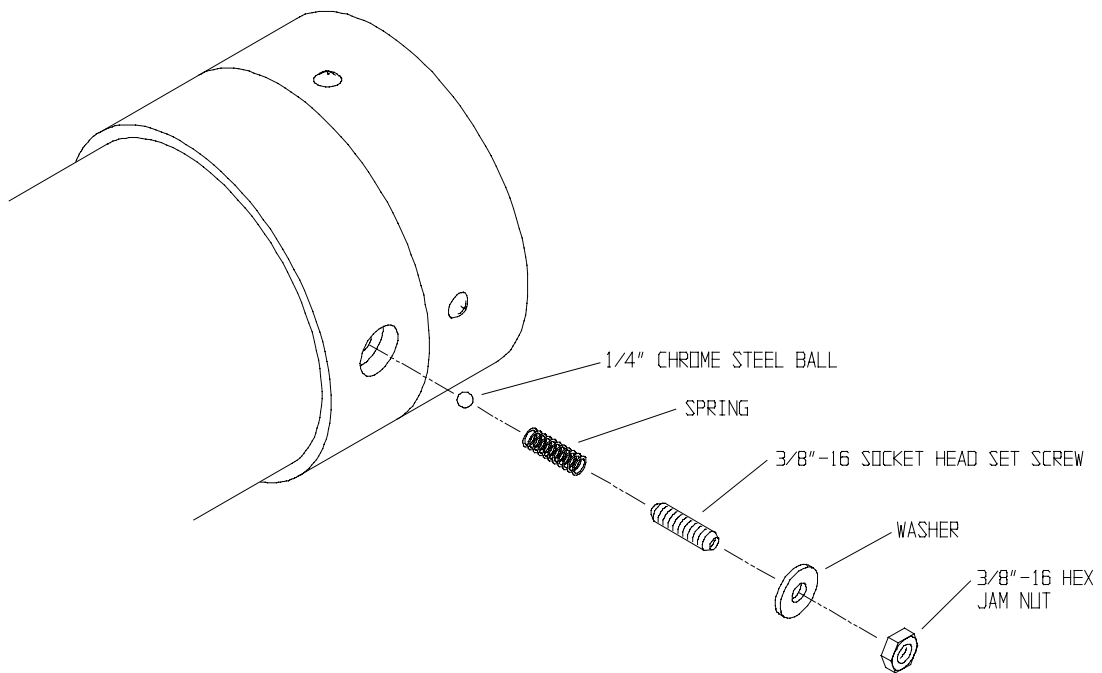

## **TROUBLESHOOTING GUIDE**

<b>PROBLEM</b>	<b>POSSIBLE CAUSE</b>	<b>SOLUTION</b>
Batteries won't charge	<p>Not using Deep Cycle Batteries</p> <p>Faulty Battery(s)</p> <p>Not following recharging directions</p> <p>Bad Circuit Breaker</p> <p>Improper grounding/wiring</p>	<p>Acquire (2) 12 Volt Deep Cycle Batteries (Group 27)</p> <p>Load test Batteries to ensure they are good</p> <p>Refer to Battery Charging Instructions (Page 5)</p> <p>Call factory for replacement</p> <p>Tighten Charger mounting bolts and check wiring</p>
Unit not functioning	<p>Low/Dead Batteries</p> <p>Improper grounding</p> <p>Damaged or loose wiring</p>	<p>Recharge Batteries</p> <p>Check Motor &amp; Battery wire connections. Tighten if necessary</p> <p>Check wiring to switches in Control Box. Re-attach loose connections</p> <p>Ensure wiring from Cord to Terminal Block has not been damaged and is still connected.</p>
Clamping function won't operate	<p>Damaged or loose wiring</p> <p>Bad Switch(es)</p> <p>Not pressing both switches</p>	<p>Check wiring to Switches &amp; wiring within the Power Pak</p> <p>Call factory to replace</p> <p>Both ON/Off Switch &amp; Clamp Switch must be depressed at the same time for unit to clamp or unclamp.</p>
Unit is crushing drums	<p>Too much pressure applied</p>	<p>Grip drum just to the point that the drum starts distorting.</p>

## Warranty & Limitation of Liability

Valley Craft products are warranted for a period of one (1) year from date of shipment from Valley Craft's plant to be free from defects in material and workmanship under correct use, normal operating and proper application. However, parts of other than Valley Craft manufacture are subject **ONLY** to the original manufacturer's warranty. Valley Craft's obligation under warranty shall be limited to repair or exchange, at Valley Craft's option, FOB origin factory, of any Valley Craft product or part which proves to be defective as provided herein. Valley Craft reserves the right to either inspect the product at Buyer's location, or require it to be returned to the factory for inspection. The warranty contained herein does not extend to goods damaged, or subject to accident, abuse or misuse after shipment from Valley Craft's factory, nor to goods altered or repaired by anyone other than an authorized Valley Craft representative.

Buyer or user shall not alter, modify or use a Valley Craft product for anything other than its intended function. Valley Craft shall not in any way be responsible for the consequences of any such alteration, modification or misuse.

VALLEY CRAFT MAKES NO EXPRESS WARRANTIES OTHER THAN THOSE WHICH ARE SPECIFICALLY DESCRIBED HEREIN. Any description of the goods sold hereunder, including any references to Buyer's specifications and any descriptions in catalogs, circulars and other written material published by Valley Craft, is for the sole purpose of identifying such goods and shall not create an express warranty that the goods shall conform to such description.

THIS WARRANTY IS EXPRESSLY IN LIEU OF ALL OTHER WARRANTIES, EXPRESS OR IMPLIED. THERE ARE NO IMPLIED WARRANTIES OF MERCHANTABILITY OR FITNESS FOR A PARTICULAR PURPOSE. THIS WARRANTY STATES VALLEY CRAFT'S ENTIRE AND EXCLUSIVE LIABILITY, AND BUYER'S EXCLUSIVE REMEDY FOR ANY CLAIM FOR DAMAGES IN CONNECTION WITH VALLEY CRAFT PRODUCTS, THEIR DESIGN, SUITABILITY FOR USE, INSTALLATION OR OPERATION OR FOR ANY CLAIMED DEFECTS. VALLEY CRAFT WILL IN NO EVENT BE LIABLE FOR INCIDENTAL OR CONSEQUENTIAL DAMAGES WHATSOEVER, NOR FOR ANY SUM IN EXCESS OF THE PRICE RECEIVED FOR THE GOODS FOR WHICH LIABILITY IS CLAIMED.

## Technical Assistance/Warranty Procedure

### What's Covered:

- Parts and Labor to correct manufacturer's defect within one year of purchase.
- Freight Cost

### What's Not:

- Normal wear items (seal kits, bearings, tires, etc.)

### What Voids the Warranty:

- Dirt/Grime that directly causes malfunction of product
  - Abuse (i.e. Overloading, damaged, not properly maintained, etc.)
  - Product altered by customer
- \*See "Items not Under Warranty" below for items that have the warranty voided.

### Items Under Warranty (less than one year old):

- Warranty replacement parts are provided only when the problem can be identified with near certainty. If not, the customer will return item to Valley Craft, freight collect, for troubleshooting and/or repair. When repaired, product will be returned to customer, freight prepaid. Otherwise, customer may call local authorized service technician for assistance. . Under this arrangement, replacement parts will be sent at no charge but labor costs will NOT be covered.

### Items NOT Under Warranty (greater than one year old or \*having warranty voided):

- Customer will return item to Valley Craft, freight prepaid, for troubleshooting and/or repair. Valley Craft will call customer with \$\$ estimate of parts and labor for approval before repairing. Product will be returned to customer, freight collect.

Or

- Customer may call local authorized service technician for repairs at their own expense.

24008 VZ

## DEXRON III AND MERCON

### # 1. CHEMICAL PRODUCT/COMPANY IDENTIFICATION

#### DEXRON III AND MERCON AUTOMATIC TRANSMISSION FLUID

MSDS Code: ATFC0051

Revised: 02-Aug-2000

"DEXRON" is a registered trademark of General Motors Corp.

"MERCON" is a registered trademark of Ford Motor Company.

Conoco Blend Code: 6682

#### MANUFACTURER/DISTRIBUTOR

Conoco Inc.

P.O. Box 2197

Houston, TX 77252

#### PHONE NUMBERS

Product Information: 1-281-293-5550

Transport Emergency: CHEMTREC 1-800-424-9300 (U.S. & Canada)  
703-527-3887 (elsewhere; call collect)

Medical Emergency: 1-800-342-5119 or 281-493-2767

### 2. COMPOSITION/INFORMATION ON INGREDIENTS

Components	%
Highly refined base oils	>70
Proprietary Additives	<30

If oil mist is generated, exposure limits apply. (See Section 8.)

### 3. HAZARDS IDENTIFICATION

#### --- EMERGENCY OVERVIEW ---

#### APPEARANCE / ODOR

Red liquid / mild petroleum hydrocarbon odor.

#### OSHA REGULATORY STATUS

This material is classified as nonhazardous under OSHA Regulations.

#### HMIS RATING

Health: 1; Flammability: 1; Reactivity: 0

#### Potential Health Effects

Primary Route of Entry: Skin

The product, as with many petroleum products, may cause minor skin, eye, and lung irritation, but good hygienic practices can minimize these effects.

Normal use of this product does not result in generation of an oil mist. However if an oil mist is generated, overexposure can cause minor and reversible irritation to the eyes, skin, and especially the lungs. Proper personal protective equipment and sufficient ventilation can provide adequate protection.

#### Carcinogenicity Information

None of the components present in this material at concentrations equal to or greater than 0.1% are listed by IARC, NTP, OSHA or ACGIH as a carcinogen.

---

#### 4. FIRST AID MEASURES

---

##### Inhalation

If inhaled, remove to fresh air. If not breathing, give artificial respiration. If breathing is difficult, give oxygen. Call a physician.

##### Skin Contact

Wash skin thoroughly with soap and water. If irritation develops and persists, consult a physician.

##### Eye Contact

In case of contact, immediately flush eyes with plenty of water at least 15 minutes. Call a physician.

##### Ingestion

Material poses an aspiration hazard. If swallowed, do not induce vomiting. Immediately give 2 glasses of water. Never give anything by mouth to an unconscious person. Call a physician.

If vomiting occurs naturally, have victim lean forward to reduce the risk of aspiration.

##### Notes to Physicians

Activated charcoal mixture may be administered. To prepare activated charcoal mixture, suspend 50 grams activated charcoal in 400 mL water and mix thoroughly. Administer 5 mL/kg, or 350 mL for an average adult.

---

#### # 5. FIRE FIGHTING MEASURES

---

##### Flammable Properties

Flash Point (minimum) : 351 F (177 C)  
(typical) 356 F (180 C)  
Method : COC

NFPA Classification : Class **IIIB** Combustible Liquid.  
NFPA Rating : Health 0; Flammability 1; Reactivity 0

##### Extinguishing Media

Water Spray, Foam, Dry Chemical, CO2.

##### Fire Fighting Instructions

Water or foam may cause frothing. Use water to keep fire-exposed containers cool. Water may be used to flush spills away from exposures.

Products of combustion may contain carbon monoxide, carbon dioxide, **and** other toxic materials. Do not enter enclosed or confined space without proper protective equipment including respiratory protection.

---

#### 6. ACCIDENTAL RELEASE MEASURES

---

##### Safeguards (Personnel)

NOTE: Review FIRE FIGHTING MEASURES and HANDLING (PERSONNEL) sections before proceeding with clean-up. Use appropriate PERSONAL PROTECTIVE EQUIPMENT during clean-up.

Remove source of heat, sparks, and flame.

#### Initial Containment

Dike spill. Prevent material from entering sewers, waterways, or low areas.

#### Spill Clean Up

Recover free liquid for reuse or reclamation. Soak up with sawdust, sand, oil dry or other absorbent material.

---

### 7. HANDLING AND STORAGE

---

#### Handling (Personnel)

Avoid breathing vapors or mist. Avoid contact with eyes. Avoid prolonged or repeated contact with skin. Wash thoroughly after handling. Wash contaminated clothing prior to reuse.

#### Handling (Physical Aspects)

Close container after each use. Do not pressurize, cut, weld, braze, solder, grind, or drill on or near full or empty container. Empty container retains residue (liquid and/or vapor) and may explode in heat of a fire.

#### Storage

Store in accordance with National Fire Protection Association recommendations. Store in a cool, dry place. Store away from heat, sparks and flames, oxidizers. Close container after each use.

---

### 8. EXPOSURE CONTROLS/PERSONAL PROTECTION

---

#### Engineering Controls

##### VENTILATION

Normal shop ventilation.

#### Personal Protective Equipment

##### RESPIRATORY PROTECTION

None normally required except in emergencies or when conditions cause excessive airborne levels of mists or vapors. Select appropriate NIOSH-approved respiratory protective equipment when exposed to sprays or mists. Proper respirator selection should be determined by adequately trained personnel **and** based on the contaminant(s), the degree of potential exposure, **and** published respirator protection factors.

##### PROTECTIVE GLOVES

Should be worn when the potential exists for prolonged or repeated skin contact. NBR or neoprene recommended.

##### EYE PROTECTION

Safety glasses with side shields.

##### OTHER PROTECTIVE EQUIPMENT

Coveralls with long sleeves if splashing is probable.

#### Applicable Exposure Limits

If oil mist is generated, exposure limits apply.

PEL (OSHA) : 5 mg/m<sup>3</sup>, 8 Hr. TWA

TLV (ACGIH) : 5 mg/m<sup>3</sup>, 8 Hr. TWA, STEL 10 mg/m<sup>3</sup>

---

### 9. PHYSICAL AND CHEMICAL PROPERTIES

---

Physical Data

Boiling Point : 650-950 F (343-510 C).  
Vapor Pressure : Nil.  
Vapor Density : >1 (Air=1.0)  
% Volatiles : Nil.  
Evaporation Rate : Nil.  
Solubility in Water : Insoluble.  
Odor : Petroleum Hydrocarbon (mild).  
Form : Liquid.  
Color : Red.  
Specific Gravity : 0.86-0.87 @ 60 F (16 C).  
Pounds per Gallon : 7.2 @ 60 F (16 C)

---

10. STABILITY AND REACTIVITY

---

Chemical Stability  
Stable.

Conditions to Avoid  
Heat, sparks, and flames.

Incompatibility with Other Materials  
Incompatible or can react with oxidizers.

Decomposition  
Normal combustion forms carbon dioxide; incomplete combustion may produce carbon monoxide.

Polymerization  
Polymerization will not occur.

---

11. TOXICOLOGICAL INFORMATION

---

Animal Data  
Mouse skin painting studies have shown that highly solvent-refined petroleum distillates similar to ingredients in this product have not caused skin tumors.

---

12. ECOLOGICAL INFORMATION

---

Ecotoxicological Information  
No specific aquatic data available for this product.

---

13. DISPOSAL CONSIDERATIONS

---

Waste Disposal  
Treatment, storage, transportation, and disposal must be in accordance with applicable Federal, State/Provincial, and Local regulations. Do not flush to surface water or sanitary sewer system.

Container Disposal  
Empty drums should be completely drained, properly bunged, and promptly shipped to the supplier or a drum reconditioner. All other containers should be disposed of in an environmentally safe manner.

---

14. TRANSPORTATION INFORMATION

---

Shipping Information  
DOT: Not regulated.  
ICAO/IMO: Not restricted.

---

15. REGULATORY INFORMATION

U.S. Federal Regulations

OSHA HAZARD DETERMINATION (29 CFR 1910.1200)

Under normal conditions of use, this material is not known to be hazardous as defined by OSHA's Hazard Communication Standard, 29 CFR 1910.1200.

CERCLA/SUPERFUND (40 CFR 302)

Not applicable; this material is covered by the CERCLA petroleum exclusion.

SARA, TITLE III, 302/304 (40 CFR 355)

This material is not known to contain extremely hazardous Substances.

SARA, TITLE III, 311/312 (40 CFR 370)

Acute : No  
Chronic : No  
Fire : No  
Reactivity : No  
Pressure : No

SARA, TITLE III, 313 (40 CFR 372)

This material is not known to contain any chemical(s) at a level of 1.0% or greater (0.1% for carcinogens) on the list of Toxic Chemicals and subject to release reporting requirements.

TSCA (40 CFR 710)

Material and/or components are listed in the TSCA Inventory of Chemical Substances (40 CFR 710).

RCRA (40 CFR 261)

This material has been evaluated for RCRA characteristics **and** does not meet hazardous waste criteria if discarded in its purchased form. Because of product use, transformation, mixing, processing, etc., which may render the resulting material hazardous, it is the product user's responsibility to determine at the time of disposal whether the material meets RCRA hazardous waste criteria.

CLEAN WATER ACT (40 CFR 116.4a)

The material contains the following ingredient(s) which is considered hazardous if spilled into navigable waters and therefore reportable to the National Response Center (1-800-424-8802).

Ingredient : Petroleum Hydrocarbons.  
Reportable Quantity : Film or sheen upon or discoloration of any water surface.

State Regulations (U.S.)

CALIFORNIA "PROP 65"

The material contains ingredient(s) known to the State of California to cause cancer, birth defects, or other reproductive harm. Read **and** follow all label directions.

Ingredient : Benzene (CAS # 71-43-2) <0.0001%  
Ingredient : Aniline (CAS # 62-53-3) <0.0001%  
Ingredient : o-Toluidine (CAS # 95-53-4) <0.0001%  
Ingredient : Ethyl acrylate (CAS # 140-88-5) <0.03%

PENNSYLVANIA WORKER & COMMUNITY RIGHT TO KNOW ACT

This material is not known to contain any ingredient(s) subject to the Act.

Canadian Regulations

This is not a WHMIS Controlled Product.

---

# 16. OTHER INFORMATION

---

NOTE: This product or any other hydrocarbon-based lubricant should not be used in non-diaphragm compressors that produce "breathing air" unless the outlet is monitored continuously for carbon monoxide. These lubricants can produce carbon monoxide when subjected to high temperatures.

---

The data in this Material Safety Data Sheet relates only to the specific material designated herein and does not relate to use in combination with any other material or in any process.

Responsibility for MSDS : MSDS Coordinator  
Address : Conoco Inc.  
> : PO Box 2197  
> : Houston, TX 77252  
Telephone : 1-281-293-5550  
Web Site : [www.conoco.com](http://www.conoco.com)

# Indicates updated section.

End of MSDS

# Material Safety Data Sheet

## SUPER-STA GREASE

### # 1. CHEMICAL PRODUCT/COMPANY IDENTIFICATION

SUPER-STA Grease

MSDS Code: GREC0290

Revised: 05-Oct-2000

"SUPER-STA" is a registered trademark of Conoco.

Grade: No. 1, No. 2

Conoco Base Codes: 9029, 9030

MANUFACTURER/DISTRIBUTOR

Conoco Inc.

PO Box 2197

Houston, TX 77252

PHONE NUMBERS

Product Information : 1-281-293-5550

Transport Emergency : 1-800-424-9300 or  
1-703-527-3887 (call collect)

Medical Emergency : 1-800-342-5119 or 1-281-493-2767

### 2. COMPOSITION/INFORMATION ON INGREDIENTS

Components	CAS Number	%
Highly Solvent-Refined Base Oils		>85
Lithium Stearate Soap	7620-77-1	<10
Zinc Compound		0-1
Proprietary Additives		<10

### 3. HAZARDS IDENTIFICATION

--- EMERGENCY OVERVIEW ---

APPEARANCE / ODOR

Amber solid / mild petroleum hydrocarbon odor.

OSHA REGULATORY STATUS

This material is not known to be hazardous as defined under OSHA regulations.

HMIS RATING

Health: 1; Flammability: 1; Reactivity: 0

Potential Health Effects

Primary Route of Entry: Skin

The product, as with many petroleum products, may cause minor skin, eye, and lung irritation, but good hygienic practices can minimize these effects.

Carcinogenicity Information

None of the components present in this material at concentrations equal to or greater than 0.1% are listed by IARC, NTP, OSHA or ACGIH as a carcinogen.

### 4. FIRST AID MEASURES

First Aid

INHALATION

If inhaled, remove to fresh air. If not breathing, give artificial respiration. If breathing is difficult, give oxygen. Call a physician.

SKIN CONTACT

Wipe off excess with towel. Wash skin thoroughly with soap and water. If irritation develops and persists, consult a physician. If injected under the skin, necrosis could occur. See physician.

EYE CONTACT

In case of contact, immediately flush eyes with plenty of water for at least 15 minutes. Call a physician.

## INGESTION

If swallowed, do not induce vomiting. Immediately give 2 glasses of water. Never give anything by mouth to an unconscious person. Call a physician.

### Notes to Physicians

Activated charcoal mixture may be administered. To prepare activated charcoal mixture, suspend 50 grams activated charcoal in 400 mL water and mix thoroughly. Administer 5 mL/kg, or 350 mL for an average adult.

High velocity injection under the skin can cause a bloodless puncture wound and result in necrosis. Immediate attention by a surgical specialist is recommended.

---

## 5. FIRE FIGHTING MEASURES

---

### Flammable Properties

Flash Point : 500 F (260 C) (Base Oil)  
Method : Cleveland Open Cup - COC.  
Autoignition : Not Available  
NFPA Classification : Class IIIB Combustible Liquid.  
NFPA Rating : Health 0; Flammability 1; Reactivity 0.

### Extinguishing Media

Water Spray, Foam, Dry Chemical, CO2.

### Fire Fighting Instructions

Water or foam may cause frothing. Use water to keep fire-exposed containers cool. Water may be used to flush spills away from exposures.

Products of combustion may contain carbon monoxide, carbon dioxide, and other toxic materials. Do not enter enclosed or confined space without proper protective equipment including respiratory protection.

---

## 6. ACCIDENTAL RELEASE MEASURES

---

### Safeguards (Personnel)

NOTE: Review FIRE FIGHTING MEASURES and HANDLING (PERSONNEL) sections before proceeding with clean-up. Use appropriate PERSONAL PROTECTIVE EQUIPMENT during clean-up.

### Spill Clean Up

Recover undamaged and minimally contaminated material for reuse and reclamation. Soak up with sawdust, sand, oil dry or other absorbent material. Shovel or sweep up.

---

## 7. HANDLING AND STORAGE

---

### Handling (Personnel)

Avoid contact with eyes. Avoid prolonged or repeated contact with skin. Wash thoroughly after handling. Wash contaminated clothing prior to reuse.

### Handling (Physical Aspects)

Close container after each use. Do not pressurize, cut, weld, braze, solder, grind, or drill on or near full or empty container. Empty container retains residue (liquid and/or vapor) and may explode in heat of a fire.

### Storage

Store in accordance with National Fire Protection Association recommendations. Store away from oxidizers, heat, sparks and flames.

---

## 8. EXPOSURE CONTROLS/PERSONAL PROTECTION

---

### Engineering Controls

#### VENTILATION

Normal shop ventilation.

### Personal Protective Equipment

#### RESPIRATORY PROTECTION

None normally required except under unusual circumstances such as described under fire fighting measures.

#### PROTECTIVE GLOVES

Should be worn when the potential exists for prolonged or repeated skin contact. NBR or neoprene recommended.

#### EYE PROTECTION

Safety glasses with side shields.

#### OTHER PRECAUTIONS

Avoid prolonged skin contact by practicing good personal hygiene and laundering contaminated clothing.

#### Exposure Limits

PEL (OSHA) : None Established  
TLV (ACGIH) : None Established

---

### 9. PHYSICAL AND CHEMICAL PROPERTIES

---

#### Physical Data

Boiling Point : Not Applicable  
Vapor Pressure : Nil  
Vapor Density : >1 (Air=1.0)  
% Volatiles : Nil  
Evaporation Rate : Nil  
Solubility in Water : Insoluble  
Odor : Petroleum Hydrocarbon (mild).  
Form : Solid.  
Color : Amber.  
Specific Gravity : Not Available  
Density : 7.1-7.2 lb/gal @ 60 F (16 C)

---

### 10. STABILITY AND REACTIVITY

---

#### Chemical Stability

Stable.

#### Conditions to Avoid

Heat, sparks, and flames.

#### Incompatibility with Other Materials

Incompatible or can react with strong oxidizers.

#### Decomposition

Normal combustion forms carbon dioxide; incomplete combustion may produce carbon monoxide.

#### Polymerization

Polymerization will not occur.

---

### 11. TOXICOLOGICAL INFORMATION

---

#### Animal Data

Mouse skin painting studies have shown that highly refined petroleum lube base oils similar to ingredients in this product have not caused skin tumors.

Animal skin exposure studies show high concentrations of zinc organic phosphates cause testicular atrophy, but this effect appears related to stress from the chemical causing severe skin irritation. Low concentrations of the zinc component, as occurs in lubricant products, would be unlikely to cause testicular damage.

---

### 12. ECOLOGICAL INFORMATION

---

#### Ecotoxicological Information

No specific aquatic data available for this product.

---

### 13. DISPOSAL CONSIDERATIONS

---

#### Waste Disposal

Treatment, storage, transportation, and disposal must be in accordance with applicable Federal, State/Provincial, and Local regulations. Incinerate material in accordance with Federal, State/Provincial and Local requirements. Do not flush to surface water or sanitary sewer system.

Container Disposal

Empty drums should be completely drained, properly bunged, and promptly shipped to the supplier or a drum reconditioner. All other containers should be disposed of in an environmentally safe manner.

---

14. TRANSPORTATION INFORMATION

---

Shipping Information

DOT: Not regulated.  
ICAO/IMO: Not restricted.  
Canada: Not regulated.

---

15. 15. REGULATORY INFORMATION

---

U.S. Federal Regulations

OSHA HAZARD DETERMINATION

This material is not known to be hazardous as defined by OSHA's Hazard Communication Standard, 29 CFR 1910.1200.

CERCLA/SUPERFUND

Not applicable; this material is covered by the CERCLA petroleum exclusion.

SARA, TITLE III, 302/304

This material is not known to contain extremely hazardous substances.

SARA, TITLE III, 311/312

Acute : No  
Chronic : No  
Fire : No  
Reactivity : No  
Pressure : No

SARA, TITLE III, 313

This material contains the following chemical(s) at a level of 1.0% or greater (0.1% for carcinogens) on the list of Toxic Chemicals and is subject to toxic chemical release reporting requirements:

Toxic Chemical : Zinc Compound.  
CAS Number : Not available.

TSCA

Material and/or components are listed in the TSCA Inventory of Chemical Substances (40 CFR 710).

RCRA

This material has been evaluated for RCRA characteristics and does not meet hazardous waste criteria if discarded in its purchased form. Because of product use, transformation, mixing, processing, etc., which may render the resulting material hazardous, it is the product user's responsibility to determine at the time of disposal whether the material meets RCRA hazardous waste criteria.

CLEAN WATER ACT

The material contains the following ingredient(s) which is considered hazardous if spilled into navigable waters and therefore reportable to the National Response Center (1-800-424-8802).

Ingredient : Petroleum Hydrocarbons.  
Reportable Quantity : Film or sheen upon or discoloration of any water surface.

State Regulations (U.S.)

CALIFORNIA "PROP 65"

This material is not known to contain any ingredient(s) subject to the Act.

PENNSYLVANIA WORKER & COMMUNITY RIGHT TO KNOW ACT

This material may contain the following ingredient(s) subject to the Pennsylvania Worker and Community Right to Know Hazardous

Substances List.  
Ingredient : Zinc Compound.  
CAS Number : Not available.  
Category : Environmental Hazardous Substance.  
Canadian Regulations  
This is not a WHMIS Controlled Product.

---

16. OTHER INFORMATION

---

Sales Office Numbers:

Australia	India
Office Manager	Tel: 91-80-227 7462/7463
Office Hours 8 a.m.-5 p.m.	Fax: 91-80-221 5513
Monday-Friday (excluding holidays)	
Tel: 61-7-5452 9900	
Fax: 61-7-5452 9999	
Malaysia	Mexico
Tel: 60-3-202 5233	Tel: 0-1-800-709-1200
Fax: 60-3-202 5266	Fax: 52-5-722-1455
Singapore	Thailand
Tel: 65-536 0010	Tel: 66-2-955-0195
Fax: 65-536 0012	Fax: 66-2-955-0190
Other	
Tel: 281-293-5768	
Fax: 281-293-2287	

---

The data in this Material Safety Data Sheet relates only to the specific material designated herein and does not relate to use in combination with any other material or in any process.

Responsibility for MSDS : MSDS Coordinator  
Address : Conoco Inc.  
> : PO Box 2197  
> : Houston, TX 77252  
Telephone : 1-281-293-5550

# Indicates updated section.

End of MSDS